

## CBT 400 POMPĂ CENTRIFUGALĂ CU 2 TURBINE

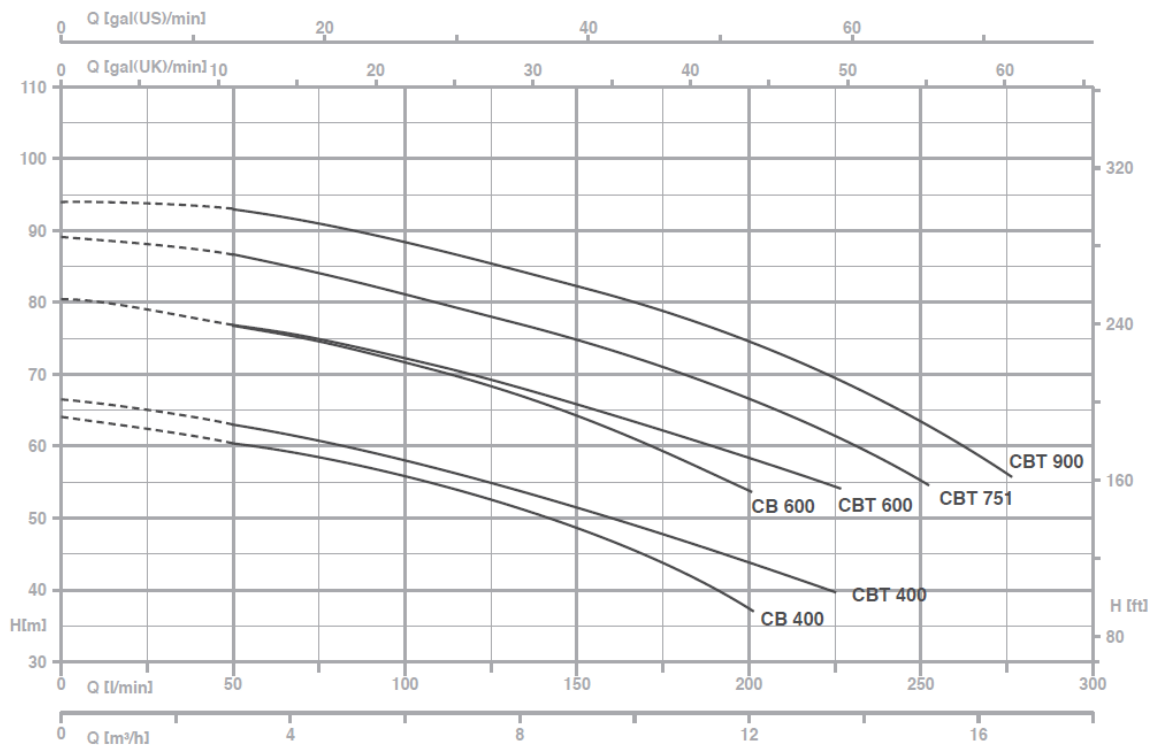



Putere absorbită P1:	4.6 kW
Putere P2:	3 kW
Alimentare:	400 V / 50 Hz
Înălțime de refulare max.:	66.9 m
Debit max.:	13500 l/h
Diametru de aspirație:	1 1/2"
Diametru de refulare:	1 1/4"

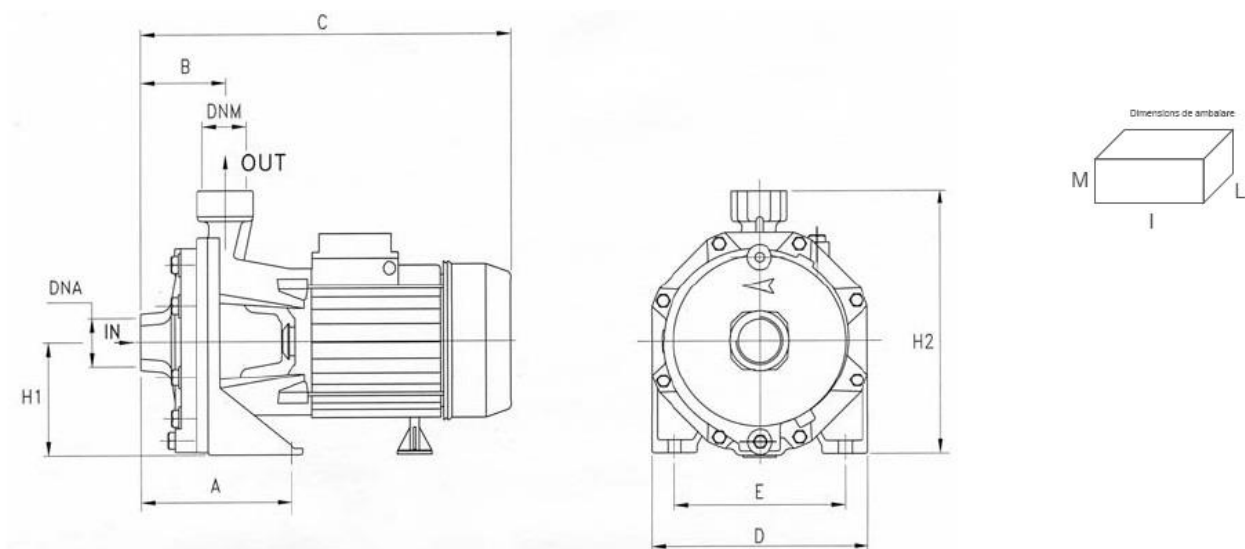

Debit Q (m <sup>3</sup> /h – l/min)									
0	1.5	3	4.5	6	7.5	9	10.5	13.5	16.5
0	25	50	75	100	125	150	175	225	275
Înălțime de refulare H (m)									
66.9	65.2	63.3	61	58.4	55.2	51.5	47.8	40.1	-

Temperatura maximă a apei:	50 °C
Carcasă pompă:	fontă
Suport motor:	fontă
Rotor pompă:	Noryl®
Etanșare mecanică:	ceramică – grafit
Arbore motor:	otel AISI 303
Clasă de izolație:	F
Clasă de protecție:	IP44



MODEL	DIMENSIUNI (mm)												
	A	B	C	D	E	H1	H2	DNA	DNM	I	L	M	
CB 100	122	72	328	180	140	98	228	1"G	1"G	350	195	265	15.3
CB 160	115	82	385	210	170	110	265	1"1/4 G	1"G	405	225	295	24.7
CB 210	115	82	385	210	170	110	265	1"1/4 G	1"G	405	2252	295	25.6
CB 310	115	82	385	210	170	110	265	1"1/4 G	1"G	405	2527	295	25.6
CB 400	145	95.5	463	266	212	135	305	1"1/2 G	1"1/4 G	500	5	3503	41